

DÖRT KÖŞE ÇEKİ OKU – DİYAGRAMLAR

Mümkün olan maksimum frensiz çeki oku uzunluğunun belirlenmesine yönelik

Düz model

Diyagram tipi R4 model B3
Dört köşe 60x60x4

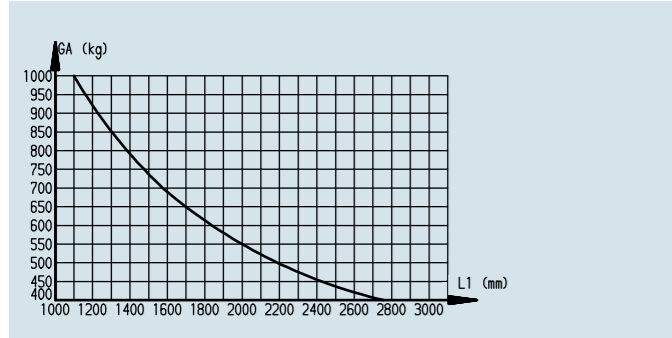

Diyagram tipi R16 model A
Dört köşe 70x70x4

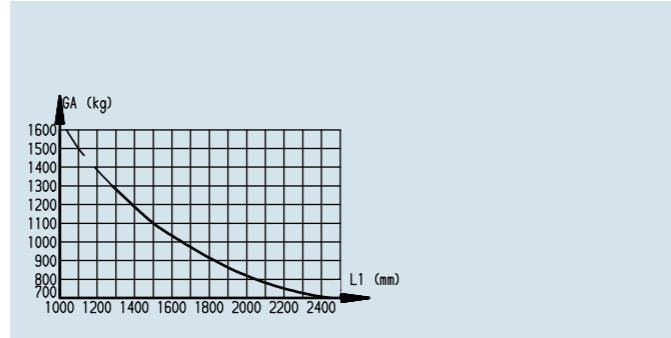

Diyagram tipi R26 model A
Dört köşe 100x100x4

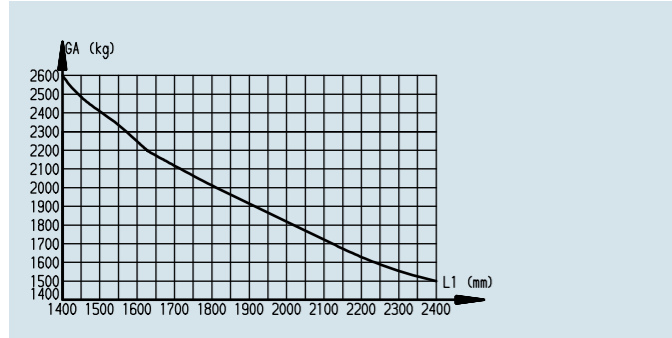

Diyagram tipi R35 model B
Dört köşe 120x120x5

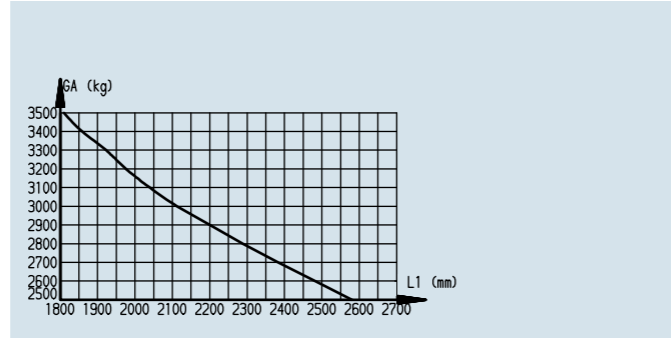

Bükümlü model

Diyagram tipi K16
Dört köşe 70x70x5

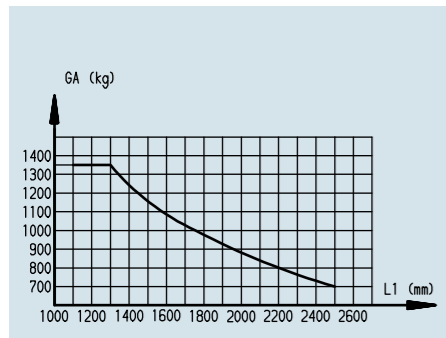

Diyagram tipi K26 model A
Dört köşe 100x100x4

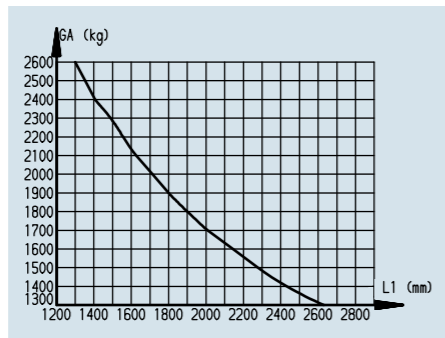

Diyagram tipi K26 model B
Dört köşe 100x100x5

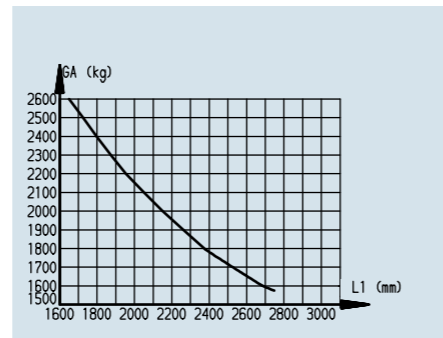

DÖRT KÖŞE ÇEKİ OKU

Kenetleme için destek mesnetleri

Teslimat kapsamı

! Cıvata malzemesiz kenetleme askılı destek mesnedi

Dış yüzey işleme

! Galvanizli

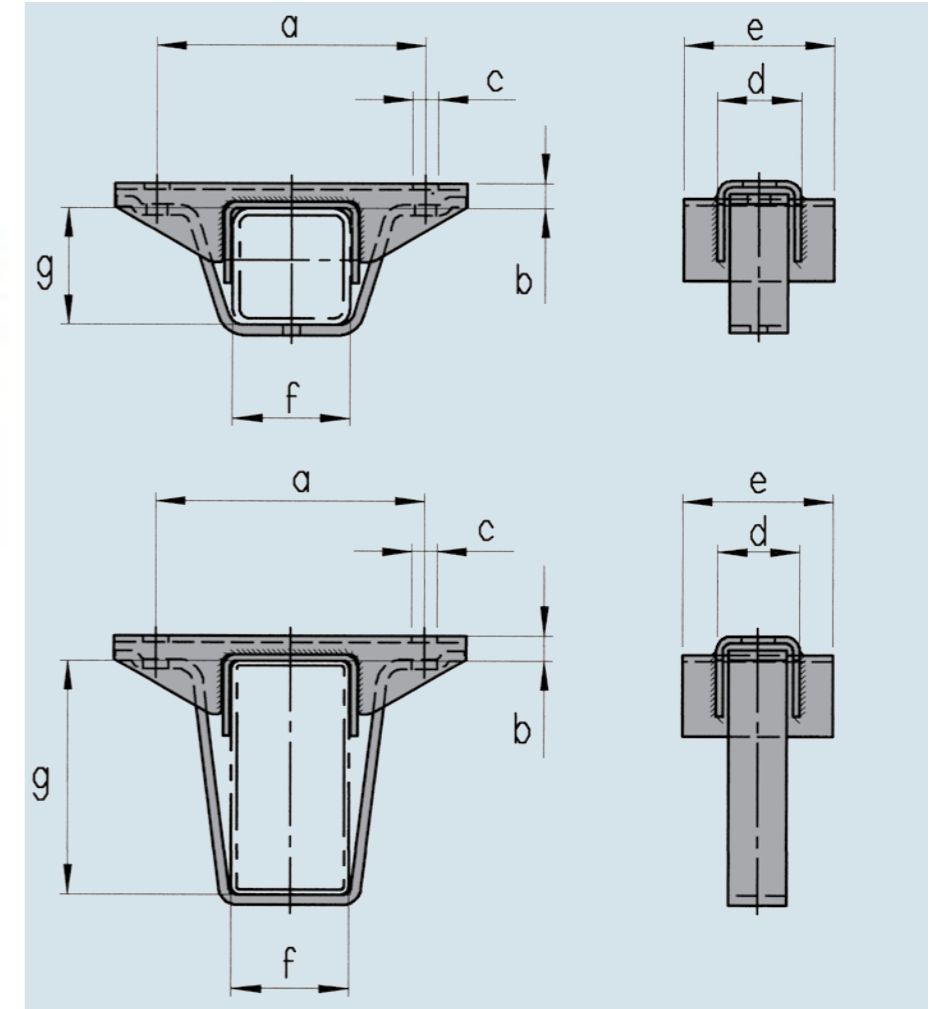

Sipariş özeti

Sipariş no.	Frensiz çeki oku borusu için bkz. mm olarak taslak f ve g ölçüsü	a ölçüsü mm	b ölçüsü mm	c ölçüsü mm	d ölçüsü mm	e ölçüsü mm				
249 317	60 x 60	160	15	13	50	-	0,9	-	350	2
247 657	70 x 70	160	15	13	50	90	1,1	-	350	2
1 211 104	70 x 140	160	15	15	50	90	1,5	-	150	2
1 210 617	80 x 140	160	15	15	60	100	1,6	-	150	2
247 638	100 x 100	160	21	13	60	100	1,6	-	150	2
1 211 105	100 x 160	200	25	17	60	120	1,8	-	150	2
1 210 475	120 x 120	220	25	17	60	120	1,8	-	150	2
1 211 106	120 x 160	220	25	17	60	120	2,0	-	150	2